

### Front Suspension

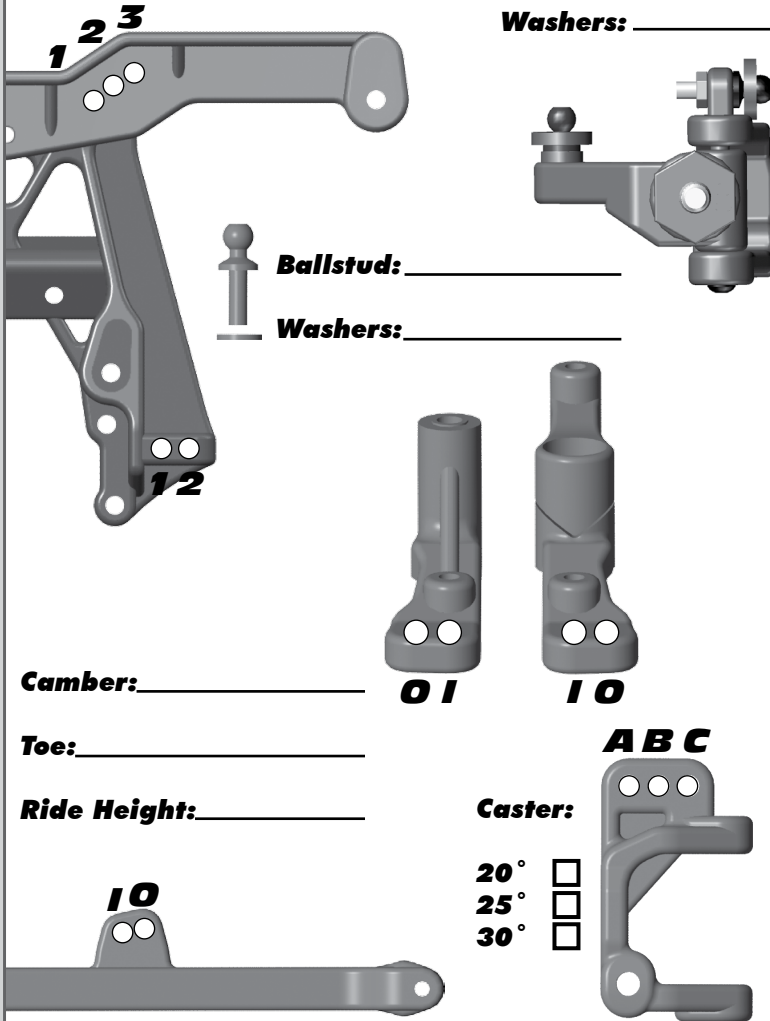

Diagram showing front suspension components with callouts 1, 2, 3 for the upper control arm and 1, 2 for the lower control arm.

**Washers:** \_\_\_\_\_

**Ballstud:** \_\_\_\_\_

**Washers:** \_\_\_\_\_

**Camber:** \_\_\_\_\_

**Toe:** \_\_\_\_\_

**Ride Height:** \_\_\_\_\_

**Caster:**

20°   
 25°   
 30°

**ABC**

### Rear Suspension

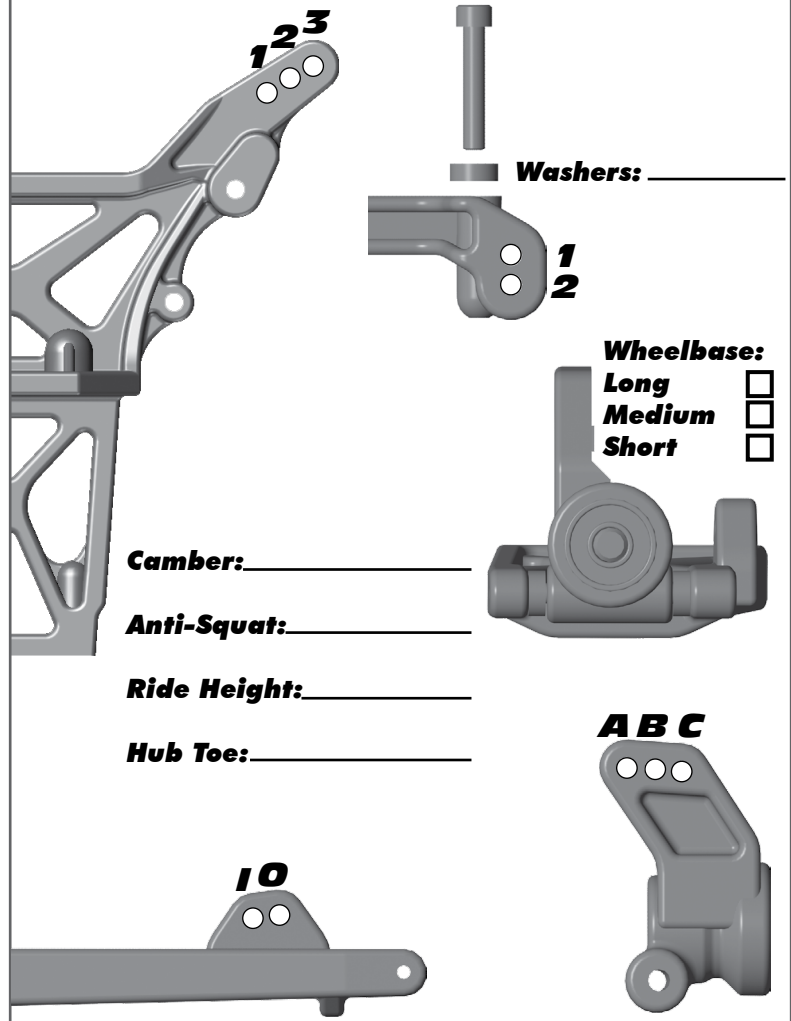

Diagram showing rear suspension components with callouts 1, 2, 3 for the upper control arm and 1, 2 for the lower control arm.

**Washers:** \_\_\_\_\_

**Wheelbase:**

Long   
 Medium   
 Short

**Camber:** \_\_\_\_\_

**Anti-Squat:** \_\_\_\_\_

**Ride Height:** \_\_\_\_\_

**Hub Toe:** \_\_\_\_\_

**ABC**

### Front Shocks

**Spring:** \_\_\_\_\_ **Piston:** \_\_\_\_\_  
**Shock Fluid:** \_\_\_\_\_ **Limiters:** \_\_\_\_\_  
**Rebound:** \_\_\_\_\_

### Rear Shocks

**Spring:** \_\_\_\_\_ **Piston:** \_\_\_\_\_  
**Shock Fluid:** \_\_\_\_\_ **Limiters:** \_\_\_\_\_  
**Rebound:** \_\_\_\_\_

### Engine

**Engine:** \_\_\_\_\_ **Size:** \_\_\_\_\_  
**Restrictor:** \_\_\_\_\_ **Temp:** \_\_\_\_\_  
**Muffler:** \_\_\_\_\_  
**Glow Plug:** \_\_\_\_\_ **Fuel:** \_\_\_\_\_

**Radio:** \_\_\_\_\_ **Brake Bias:** \_\_\_\_\_  
**Throttle / Steering Servos:** \_\_\_\_\_/  
**Throttle / Brake e.p.a.:** \_\_\_\_\_  
**Throttle / Brake expo:** \_\_\_\_\_  
**Steering expo:** \_\_\_\_\_  
**Dual Rate:** \_\_\_\_\_

### Slipper / Gearing / Clutch

**Slipper:** \_\_\_\_\_  
**Clutch Bell / Spur Gear:** \_\_\_\_\_/  
**Clutch Shoes:** \_\_\_\_\_  
**Clutch Springs:** \_\_\_\_\_

### Chassis

**Chassis Brace:** Plastic  Aluminum  \_\_\_\_\_  
**Chassis Weight:** \_\_\_\_\_

### Front Tires

**Tire:** \_\_\_\_\_ **Compound:** \_\_\_\_\_  
**Insert:** \_\_\_\_\_ **Wheel:** \_\_\_\_\_  
**Notes:** \_\_\_\_\_

### Rear Tires

**Tire:** \_\_\_\_\_ **Compound:** \_\_\_\_\_  
**Insert:** \_\_\_\_\_ **Wheel:** \_\_\_\_\_  
**Notes:** \_\_\_\_\_

### Body

**Body Type:** \_\_\_\_\_ **Notes:** \_\_\_\_\_

### Track Info

**Smooth:**  **Bumpy:**  **Blue Groove:**   
**Traction:** **High:**  **Medium:**  **Low:**   
**Soft Dirt:**  **Grass:**  **Clay:**  **Wet:**   
**Dusty:**  **Other:** \_\_\_\_\_

### Race and Vehicle Comments

**Qualify:** \_\_\_\_\_ **Main:** \_\_\_\_\_ **Finish:** \_\_\_\_\_ **TQ:** \_\_\_\_\_  
**Comments:** \_\_\_\_\_